

DATENBLATT FÜR LIEGENDE NIEDERDRUCK CO₂ TANKANLAGEN DATA SHEET FOR HORIZONTAL LOW PRESSURE CO₂ STORAGE VESSELS

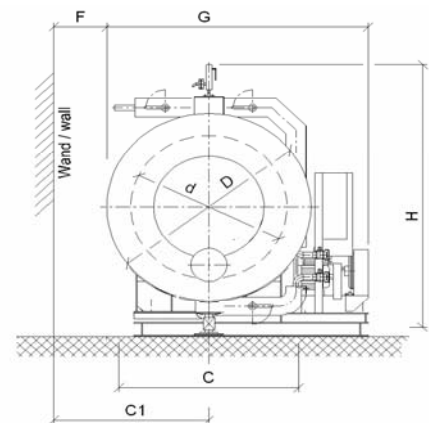
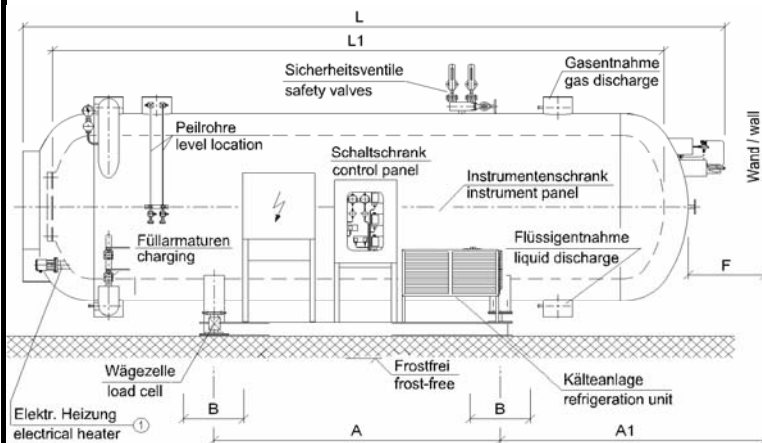

1	Typ:	Type:	*3)				E1000ND			
2	Fassungsvermögen:	Bale cubic capacity					10.000			kg
3	Betriebsgewicht:	Operating weight					17.000			kg
4	Fundamentbel. pro Sattel	Foundation load each saddle					9.000			kg
6	Anschlußspannung:	Mains voltage					400 V - 50 Hz - 3 ph			
7	Abgesicherte Zuleitung:	Protected cable	*1)				3 x 16			Amp.
8	Heizungsflansch: (DN/PN)	Flangesize of heating element					125/40			
9	Standard-Heizung:	Standard heating element					7,5			kW
10	Montagelänge Heizung:	Lenght of heating element					1.000			mm
11	Abgesicherte Zuleitung:	Protected cable	*2)				3 x 25			Amp.
12	max. inst. Heizung:	Max. heating element					15			kW
13	Montagelänge max.Heizung:	Lenght of max. heating element					1.200			mm
14	Abgesicherte Zuleitung:	Protected cable	*2)				3 x 35			Amp.
15	Behälterdurchmesser:	Diameter of storage vessel								
16	- ohne Isolierung	- without insulation	d				1.600			mm
17	- mit Isolierung	- insulated	D				2.000			mm
18	Höhe über alles:	Hight over all	H				2.730			mm
19	Gesamtlänge:	Total length	L				7.000			mm
20	Breite über alles:	Width over all	G				2.350			mm
21	Längenachmaß "L1":	Linear dimension L1	L1				5.950			mm
22	Sattelabstand:	Distance of saddle	A				3.300			mm
23	Streifenfundamentbreite:	Width of striped foundation	B				400			mm
24	Streifenfundamentlänge:	Length of striped foundation	C				1.800			mm
25	Streifenfundamenthöhe:	Hight of striped foundation	E				n.e.			mm
26	Abstandsmaß "A1":	Distance measure A1	A1				4.500			mm
27	Abstandsmaß "C1":	Distance measure C1	C1				1.800			mm
28	Freiraum um die Anlage:	Free space around the plant	F				800			mm
38	*1) Information for Storage plants with refrigeration unit.		*4) Refrigerating capacity / motor power							
39	*2) If a heating element is used the higher value is correct.		Ⓛ Pos. 8 to 14: optional (electrical heater)							
40	*3) Other sizes are request.		All indiations are approximate we keep the right of technical modifications							